

5

4

3

2

1

12/07/2021

1) Initial release

02/16/2022

1) Update to onboard JLINK solution

D

D

C

C

B

B

A

A

5

4

3

2

1

P01: Revision History

THIS DOCUMENT CONTAINS
 INFORMATION PROPRIETARY
 TO AMBIQ AND SHALL NOT BE
 USED, REPRODUCED, OR
 DISCLOSED TO OTHERS, IN
 PART OR WHOLE, WITHOUT
 EXPRESS WRITTEN PERMISSION
 FROM AMBIQ.

www.ambiq.com

		AMBIQ 5500 River Place Blvd. Building 7, Suite 200 Austin, TX 78730	
Title AMAP4PEVB			
Size	Drawn by: C Crosby	12/07/21	Document Number
C	Check by:		AMBRD-0084
	Apv'd by:		2
Date: Wednesday, February 16, 2022		Sheet 1 of 10	

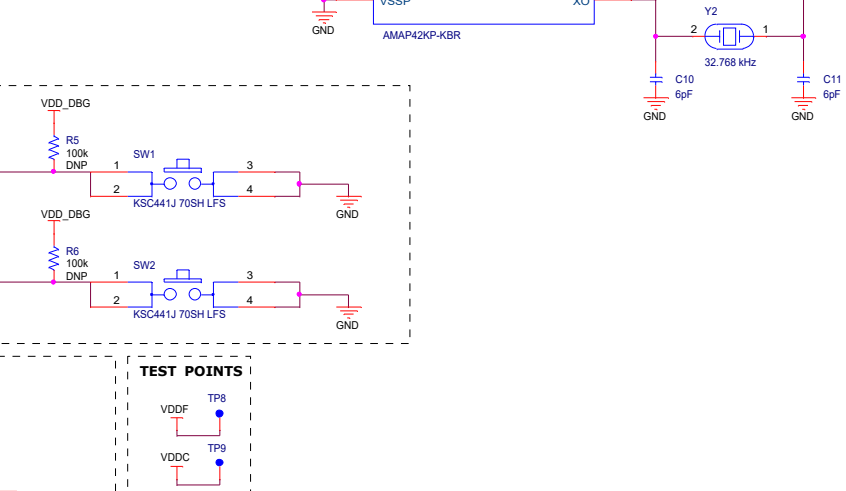
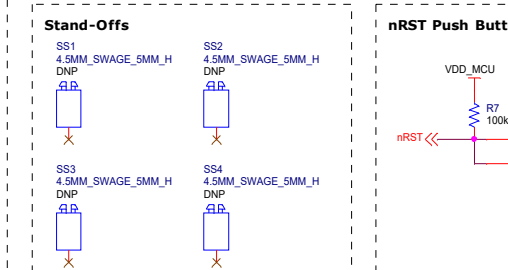
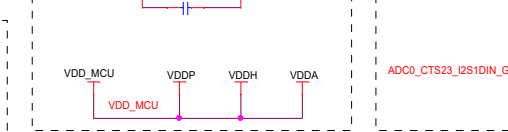
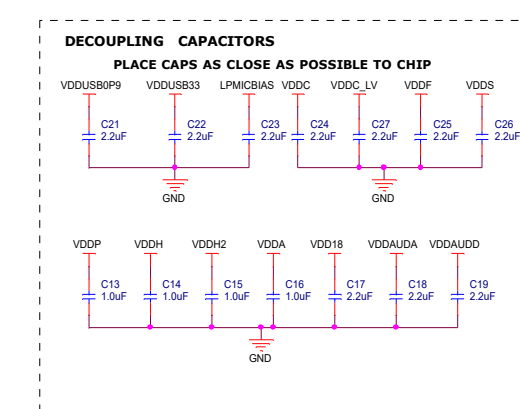
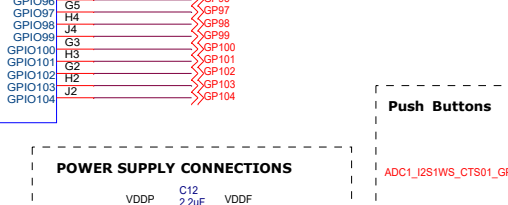
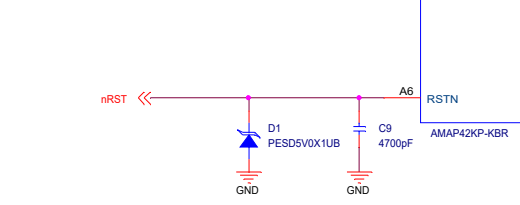
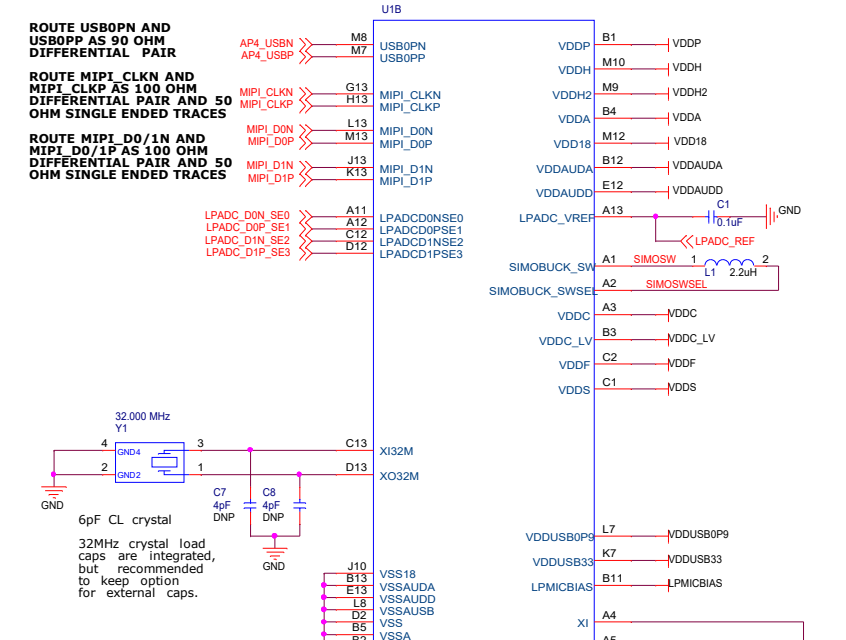
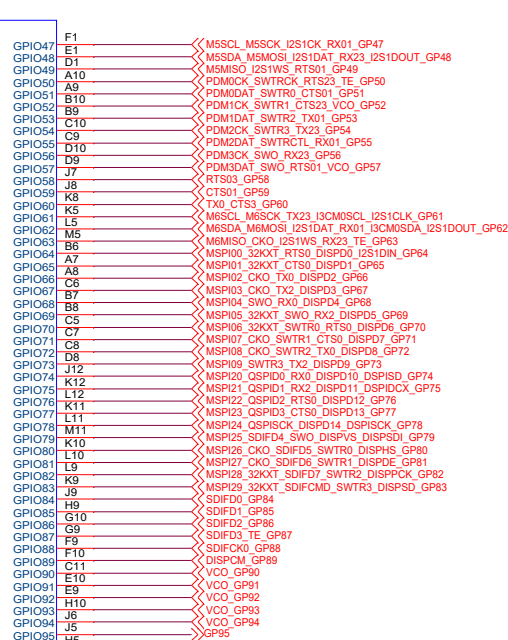
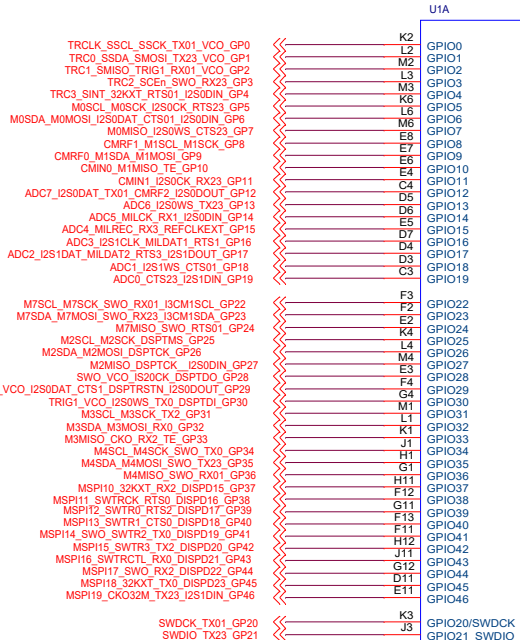

P02: Apollo 4 Plus MCU

THIS DOCUMENT CONTAINS INFORMATION PROPRIETARY TO AMBIQ AND SHALL NOT BE USED, REPRODUCED OR DISCLOSED TO OTHERS, IN PART OR WHOLE, WITHOUT EXPRESS WRITTEN PERMISSION FROM AMBIQ.

ambiq

AMBIQ
6500 River Place Blvd.
Building 7, Suite 200
Austin, TX 78730

Title: **AMAP4PEVB**

Size: **C** Drawn by: C Crosby 12/07/21 Document Number: **AMSCH-0084** Rev: **2**

Date: Wednesday, February 16, 2022

www.ambiq.com

Sheet 2 of 10

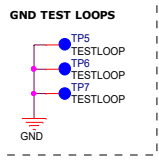
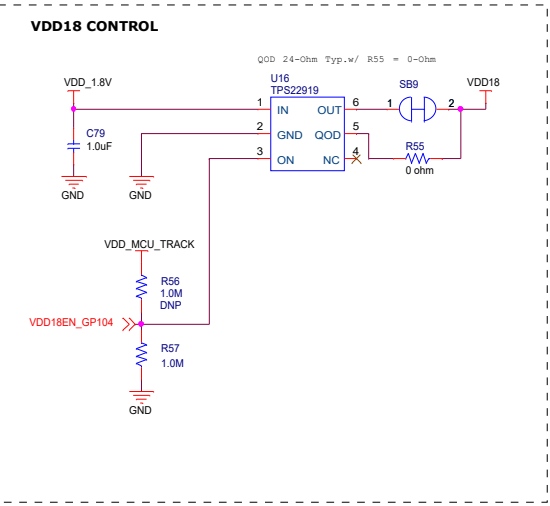
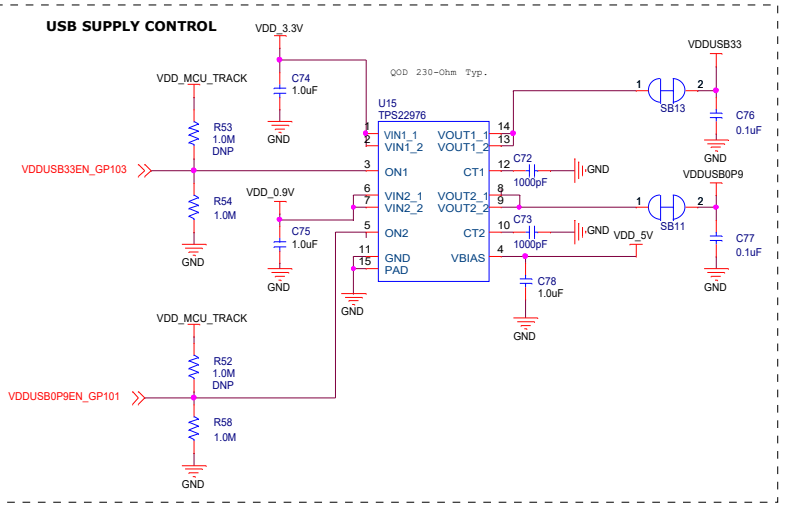
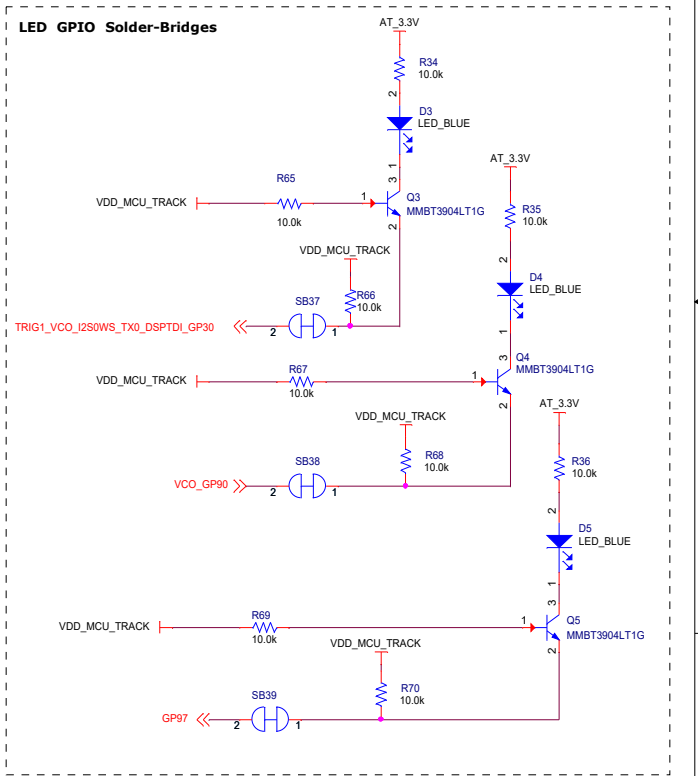
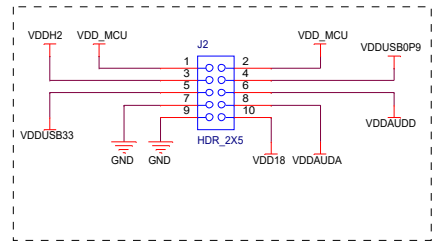
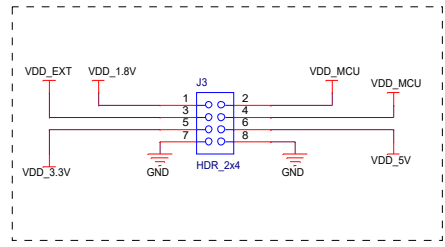
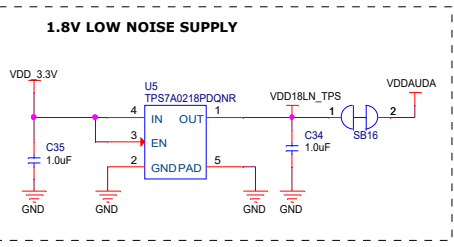
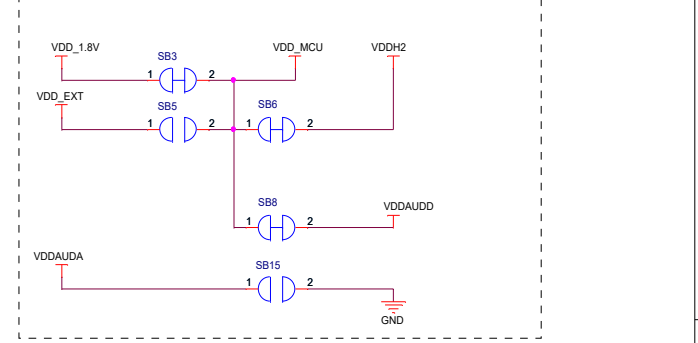
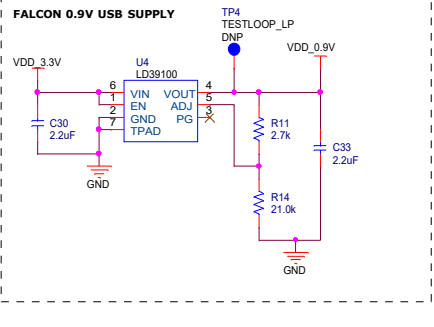
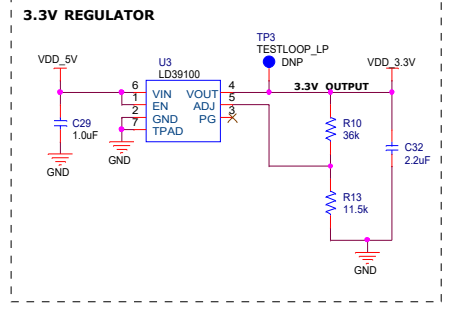
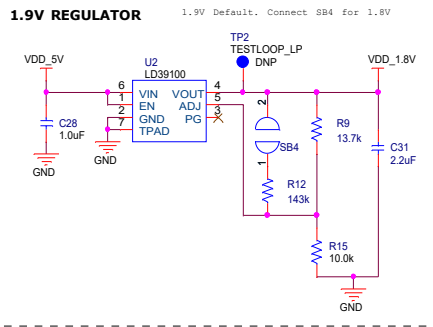

P03: Power Supplies

THIS DOCUMENT CONTAINS INFORMATION PROPRIETARY TO AMBiq AND SHALL NOT BE USED, REPRODUCED, OR DISCLOSED TO OTHERS, IN PART OR WHOLE, WITHOUT EXPRESS WRITTEN PERMISSION FROM AMBiq.

ambiq

AMBiq
6500 River Place Blvd.
Building 7, Suite 200
Austin, TX 78730

Title: **AMAP4PEVB**

Size	Drawn by: C Crosby	12/07/21	Document Number	Rev
C	Check by:		AMSCH-0084	2
	Apv'd by:			

Date: Wednesday, February 16, 2022

www.ambiq.com

Sheet 3 of 10

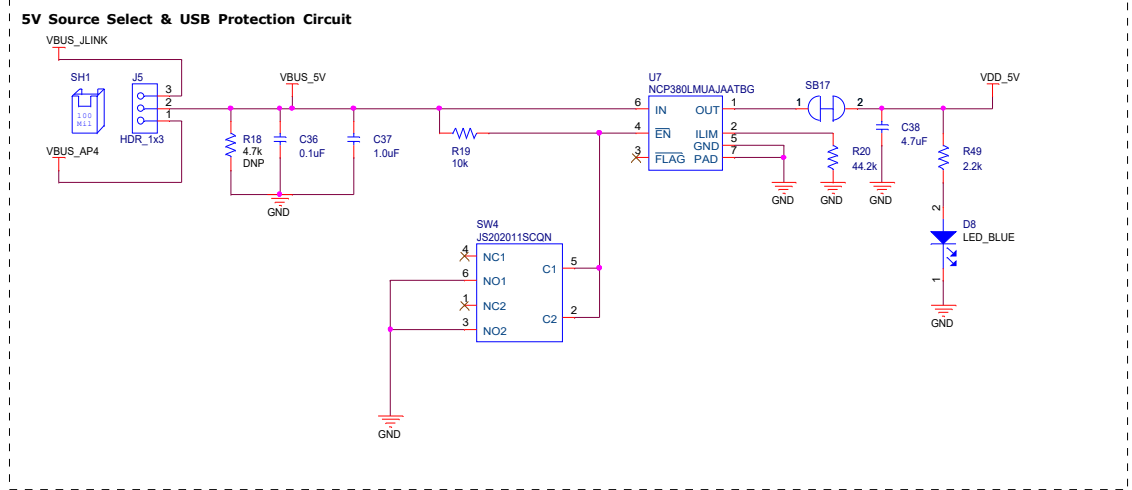
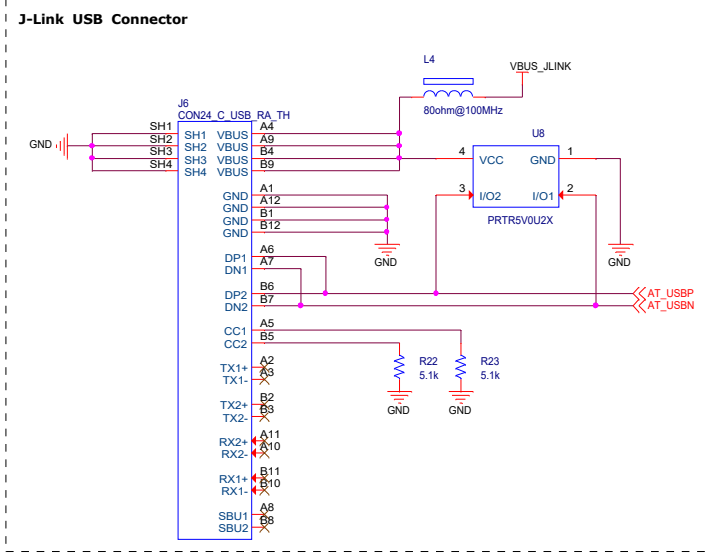
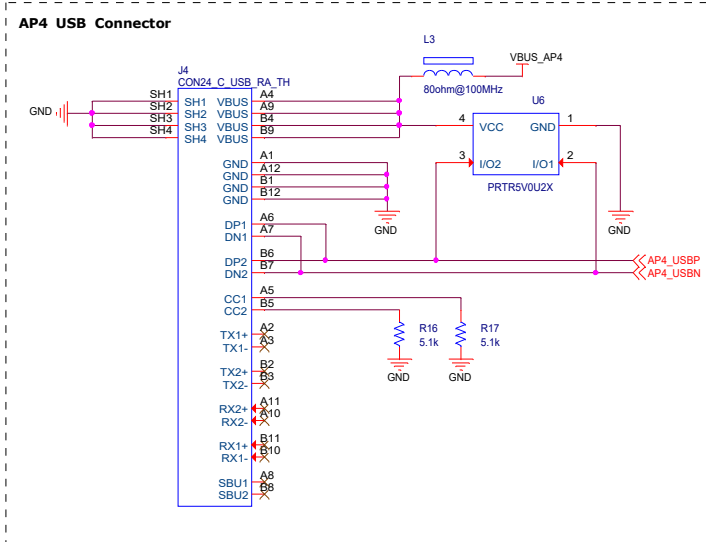

P04: USB

THIS DOCUMENT CONTAINS INFORMATION PROPRIETARY TO AMBQ AND SHALL NOT BE USED, REPRODUCED, OR DISCLOSED TO OTHERS, IN PART OR WHOLE, WITHOUT EXPRESS WRITTEN PERMISSION FROM AMBQ.				AMBQ 5500 River Place Blvd. Building 7, Suite 200 Austin, TX 78730	
Title AMAP4PEVB					
Size C	Drawn by: C Crosby Check by: Apv'd by:	12/07/21	Document Number AMSCH-0084	Rev 2	Date: Wednesday, February 16, 2022
www.ambiq.com		[Sheet 4 of 10]			

J-Link Onboard Debugger

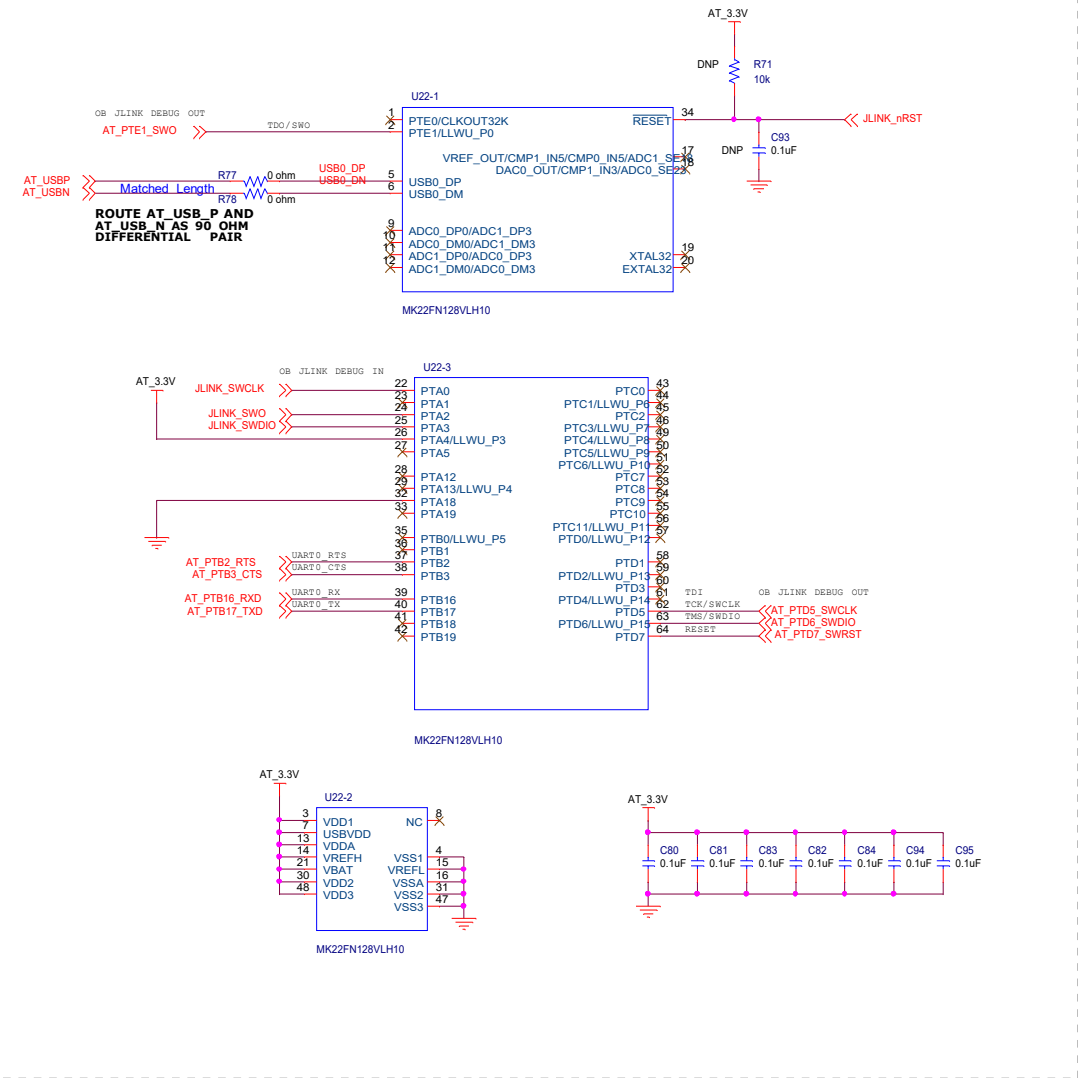

J-Link Voltage Disconnect Solder-Bridges



J-Link SWD Connections and Level Translation

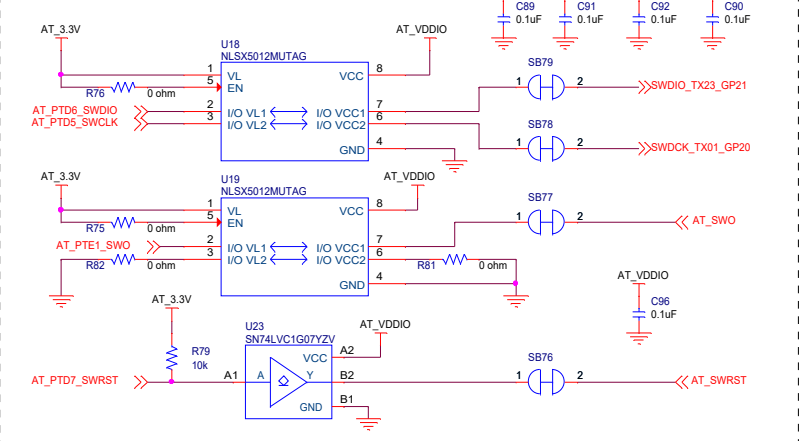

J-Link To AP4 UART Solder-Bridges and Level Translation

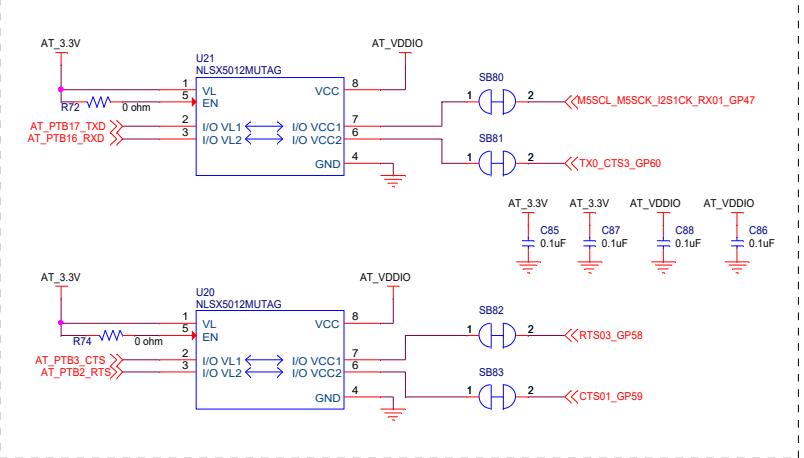

P05: Debugger

THIS DOCUMENT CONTAINS INFORMATION PROPRIETARY TO AMBiq AND SHALL NOT BE USED, REPRODUCED OR DISCLOSED TO OTHERS, IN PART OR WHOLE, WITHOUT EXPRESS WRITTEN PERMISSION FROM AMBiq.

www.ambiq.com

AMBiq
5500 River Place Blvd.
Building 7, Suite 200
Austin, TX 78730

Title: **AMAP4PEVB**

Size	Drawn by: C Crosby	12/07/21	Document Number	Rev
C	Check by:		AMSCH-0084	1
	Approved by:			2

Date: Tuesday, March 22, 2022

Sheet 5 of 10

Arduino-Style GPIO Headers

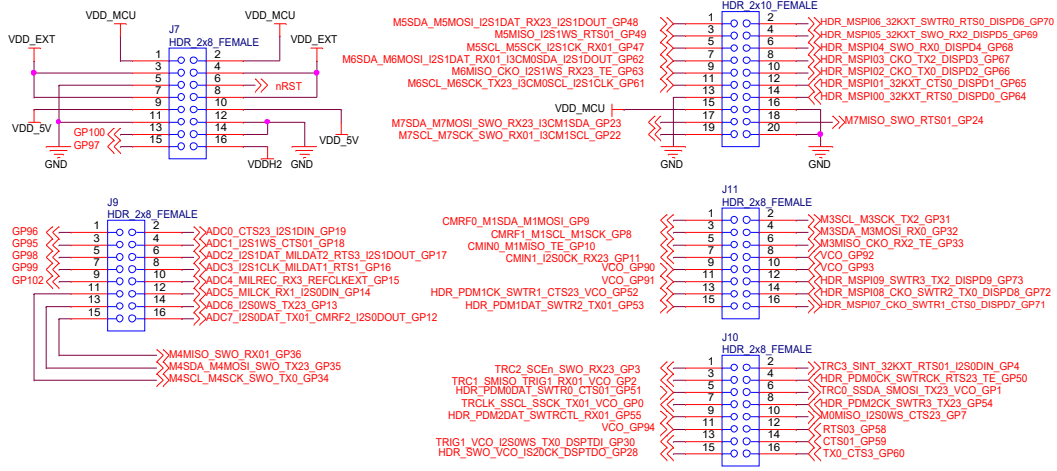

High-Speed Header

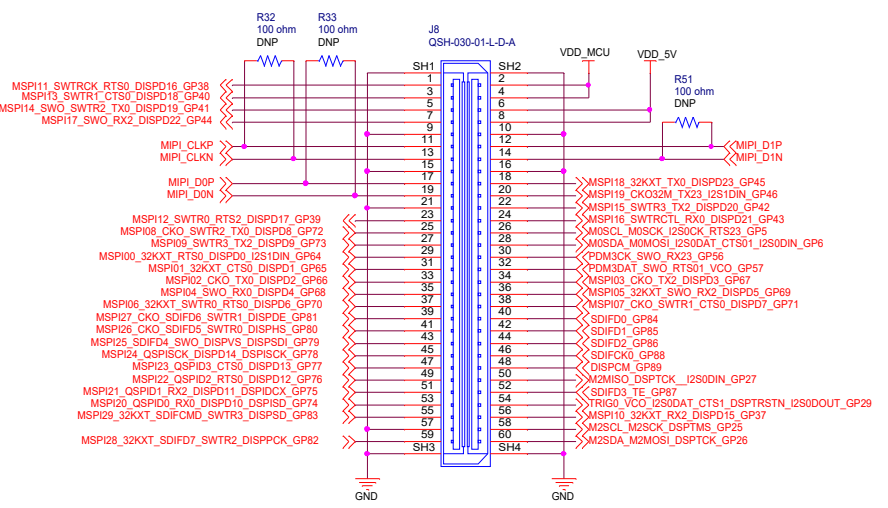

Debug Signal to GPIO Connector Solder-Bridges

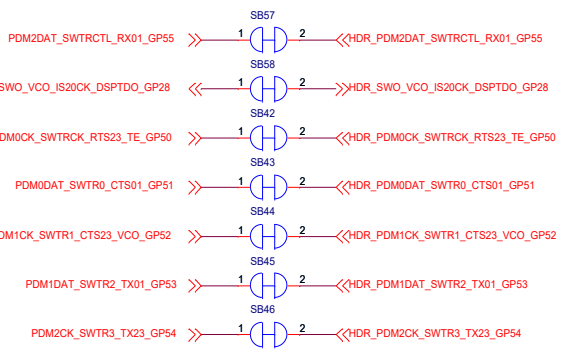

USB/MIPI Sequence Control

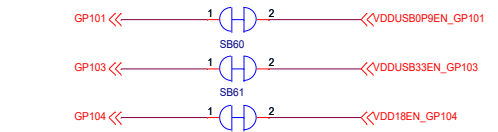

Display Controller GPIO Solder-Bridges

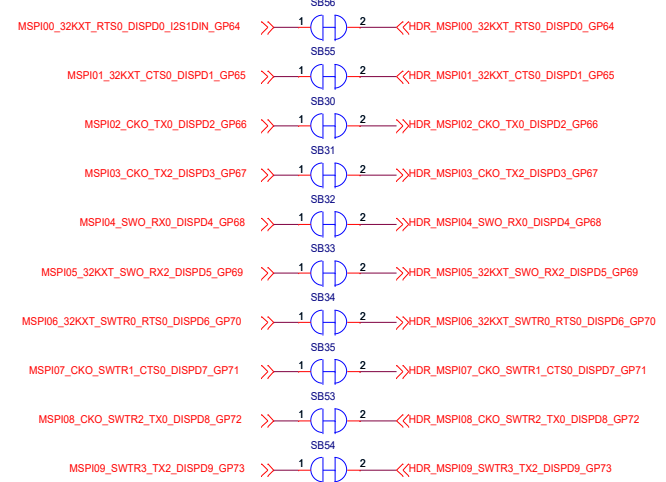

P06: GPIO Headers

THIS DOCUMENT CONTAINS INFORMATION PROPRIETARY TO AMBIQ AND SHALL NOT BE USED, REPRODUCED OR DISCLOSED TO OTHERS, IN PART OR WHOLE, WITHOUT EXPRESS WRITTEN PERMISSION FROM AMBIQ.

ambiq

AMBIQ
6200 River Place Blvd.
Building 7, Suite 200
Austin, TX 78730

Title: **AMAP4PEVB**

Size: **C** Drawn by: C Crosby 12/07/21 Document Number: **AMSCH-0084** Rev: **2**

Date: Wednesday, February 16, 2022

www.ambiq.com

Sheet 6 of 10

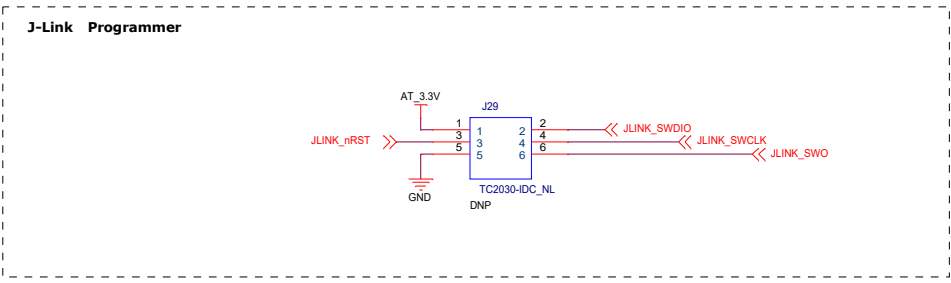
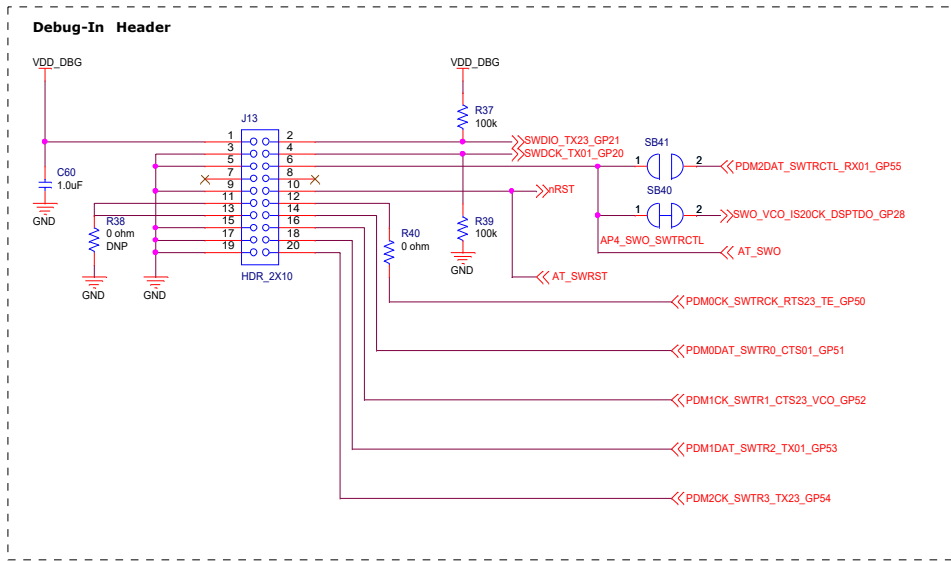

P07: Debug Headers and Support

THIS DOCUMENT CONTAINS INFORMATION PROPRIETARY TO AMBiq AND SHALL NOT BE USED, REPRODUCED, OR DISCLOSED TO OTHERS, IN PART OR WHOLE, WITHOUT EXPRESS WRITTEN PERMISSION FROM AMBiq.

www.ambiq.com

AMBiq
5500 River Place Blvd.
Building 7, Suite 200
Austin, TX 78730

Title AMAP4PEVB			
Size C	Drawn by: C Crosby	12/07/21	Document Number AMSCH-0084
Date: Wednesday, February 16, 2022	Check by:	Rev 2	Sheet 7 of 10

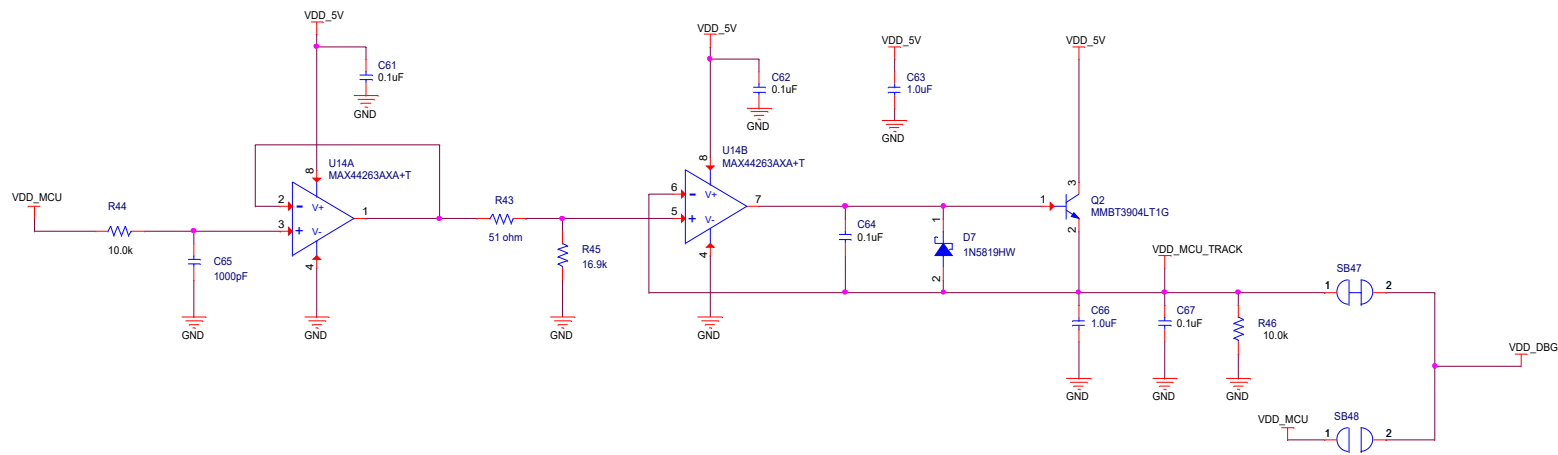

P08: Power Supply Tracker

THIS DOCUMENT CONTAINS
 INFORMATION PROPRIETARY
 TO AMBiq AND SHALL NOT BE
 USED, REPRODUCED, OR
 DISCLOSED TO OTHERS, IN
 PART OR WHOLE, WITHOUT
 EXPRESS WRITTEN PERMISSION
 FROM AMBiq.



AMBiq
 6500 River Place Blvd.
 Building 7, Suite 200
 Austin, TX 78730

www.ambiq.com

Title				AMAP4PEVB	
Size	Drawn by: C Crosby	12/07/21	Document Number		Rev
C	Check by:		AMSCH-0084		2
	Aprvd by:				
Date: Wednesday, February 16, 2022				Sheet 8 of 10	

LPADC 3.5MM Jack

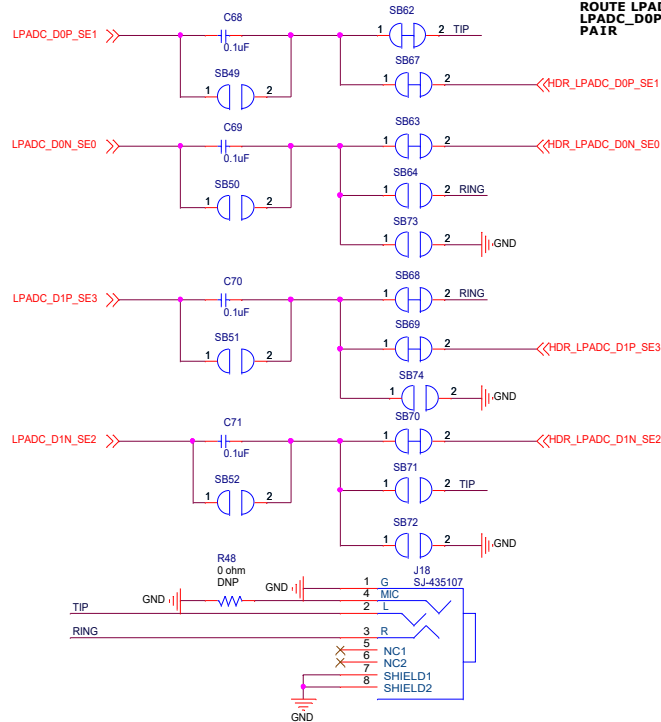

ROUTE LPADC_D1N_SE2 AND LPADC_D1P_SE3 AS DIFFERENTIAL PAIR
ROUTE LPADC_D0N_SE0 AND LPADC_D0P_SE1 AS DIFFERENTIAL PAIR

LPADC Voltage Header

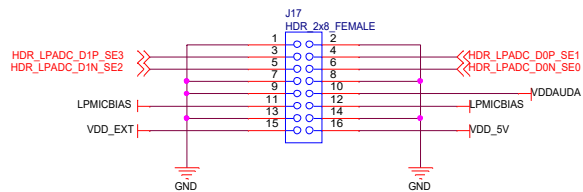

P09: Audio Connections

THIS DOCUMENT CONTAINS INFORMATION PROPRIETARY TO AMBiq AND SHALL NOT BE USED, REPRODUCED, OR DISCLOSED TO OTHERS, IN PART OR WHOLE, WITHOUT EXPRESS WRITTEN PERMISSION FROM AMBiq.

www.ambiq.com



AMBiq
 5500 River Place Blvd.
 Building 7, Suite 200
 Austin, TX 78730

Title AMAP4PEVB			
Size C	Drawn by: C Crosby	12/07/21	Document Number AMSCH-0084
Date: Wednesday, February 16, 2022	Check by: []	Approved by: []	Rev 2

J7 Testpoints

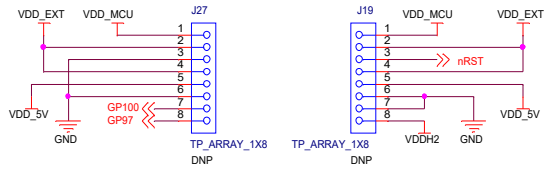

J9 Testpoints

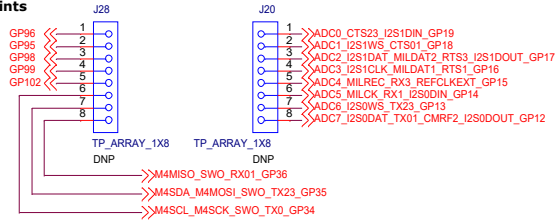

J12 Testpoints

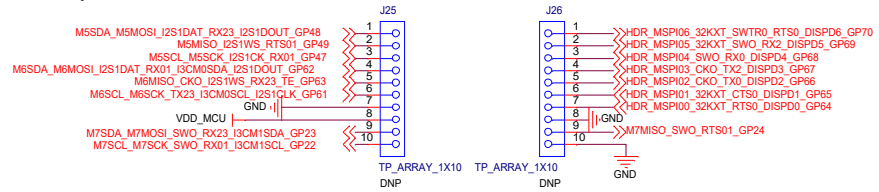

J11 Testpoints

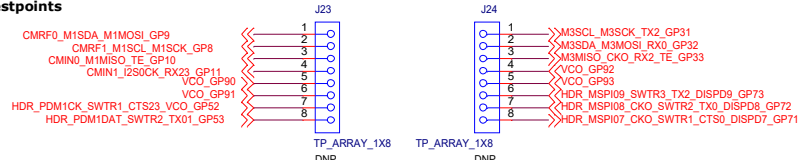

J10 Testpoints

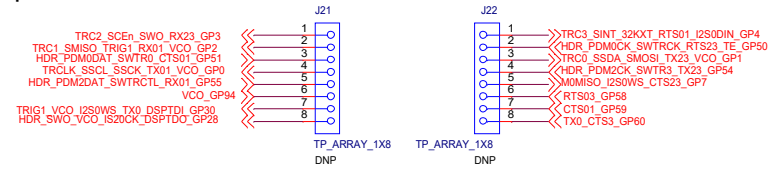

P10: Testpoint Arrays

THIS DOCUMENT CONTAINS INFORMATION PROPRIETARY TO AMBiq AND SHALL NOT BE USED, REPRODUCED, OR DISCLOSED TO OTHERS, IN PART OR WHOLE, WITHOUT EXPRESS WRITTEN PERMISSION FROM AMBiq.



AMBiq
5500 River Place Blvd.
Building 7, Suite 200
Austin, TX 78730

Title **AMAP4PEVB**

Size	Drawn by: C Crosby	12/07/21	Document Number	Rev
C	Check by:		AMSCH-0084	2
	Aprvd by:			
Date: Wednesday, February 16, 2022				Sheet 10 of 10

www.ambiq.com